



SM30/RFL25

SM30 Capacity 30,000 lbs. (15,000 lbs. per axle)
140" Minimum Wheelbase
RFL25 Capacity 25,000 lbs. (12,500 lbs. per axle)

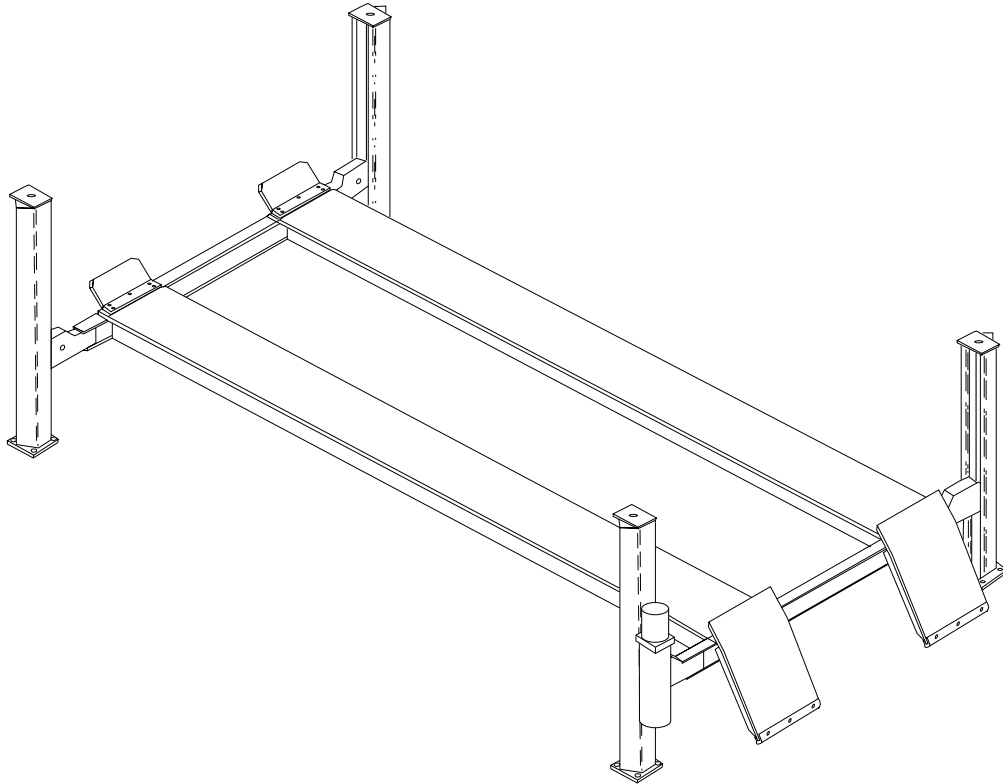

TABLE OF CONTENTS:

OWNER/EMPLOYER RESPONSIBILITIES.....	2
SAFETY INSTRUCTIONS	3
SAFETY WARNING LABELS.....	4
OPERATING INSTRUCTIONS.....	5
MAINTENANCE INSTRUCTIONS	6
TROUBLE SHOOTING	7
LIFT LOCKOUT/TAGOUT PRODEDURE.....	9
OPERATING CONDITIONS.....	10
APPROVED ACCESSORIES.....	10

LP20460

Owner/Employer Responsibilities

The Owner/Employer:

- Shall ensure that lift operators are qualified and that they are trained in the safe use and operation of the lift using the manufacturer's operating instructions; ALI/SM01-1, *ALI Lifting it Right* safety manual; ALI/ST-90 *ALI Safety Tips* card; ANSI/ALI ALOIM-2000, *American National Standard for Automotive Lifts-Safety Requirements for Operation, Inspection and Maintenance*; ALI/WL Series, *ALI Uniform Warning Label Decals/Placards*; and in the case of frame engaging lifts, ALI/LP-GUIDE, *Vehicle Lifting Points/Quick Reference Guide for Frame Engaging Lifts*.
- Shall establish procedures to periodically inspect the lift in accordance with the lift manufacturer's instructions or ANSI/ALI ALOIM-2000, *American National Standard for Automotive Lifts-Safety Requirements for Operation, Inspection and Maintenance*; and The Employer Shall ensure that lift inspectors are qualified and that they are adequately trained in the inspection of the lift.
- Shall establish procedures to periodically maintain the lift in accordance with the lift manufacturer's instructions or ANSI/ALI ALOIM-2000, *American National Standard for Automotive Lifts-Safety Requirements for Operation, Inspection and Maintenance*; and The Employer Shall ensure that lift maintenance personnel are qualified and that they are adequately trained in the maintenance of the lift.
- Shall maintain the periodic inspection and maintenance records recommended by the manufacturer or ANSI/ALI ALOIM-2000, *American National Standard for Automotive Lifts-Safety Requirements for Operation, Inspection and Maintenance*.
- Shall display the lift manufacturer's operating instructions; ALI/SM 93-1, *ALI Lifting it Right* safety manual; ALI/ST-90 *ALI Safety Tips* card; ANSI/ALI ALOIM-2000, *American National Standard for Automotive Lifts-Safety Requirements for Operation, Inspection and Maintenance*; and in the case of frame engaging lifts, ALI/LP-GUIDE, *Vehicle Lifting Points/Quick Reference Guide for Frame Engaging Lifts*; in a conspicuous location in the lift area convenient to the operator.
- Shall provide necessary lockout/tagout means for energy sources per ANSI Z244.1-1982 (R1993), *Safety Requirements for the Lockout/Tagout of Energy Sources*, before beginning any lift repairs.
- Shall not modify the lift in any manner without the prior written consent of the manufacturer.

SAFETY INSTRUCTIONS

- **Never** allow unauthorized or untrained persons to operate lift or rolling jacks.
- **Shop Policy** should prohibit customers or non-authorized persons from being in shop area while lift is in use.
- **Thoroughly** train all employees in the use and care of lift and rolling jacks.
- **Be Sure** no one is standing in front or behind lift while vehicle is being driven onto or backed off the lift.
- **DO NOT** allow rear tires or portion of vehicle to interfere with ramp/chocks.
- **Be Sure** front wheel stops are in raised position before driving vehicle onto lift.
- **Never** allow front wheels to strike the front wheel stops.
- **DO NOT** permit employees or customers on lift when it is either being raised or lowered.
- **Always** stand clear of lift when raising or lowering and observe “Pinch Points” Warning.
- **Never** overload lift: capacity of lift is 30,000 lbs. for SM30 (15,000 lbs. per axle) 25,000 lbs. for RFL25 (12,500 lbs. per axle). **CAPACITY SHOULD NOT BE EXCEEDED.**
- **Always** engage parking brake and use the rear wheel chocks to keep the vehicle from rolling freely on the runways.
- **Always** lower lift on locks before working on vehicle.
- **Keep** area around lift clean of tools, debris, grease, and oil.
- **Always** keep runway clean.
- **Replace** all caution, warning, or safety related decals on the lift when unable to read or missing.
- **For Rolling Jack Safety Instructions** see Rolling Jack Installation, Operation and Maintenance Instructions in the rolling jack box.

SAFETY WARNING LABELS for Four-Post Surface Mounted Roll-on Lifts

- A. The following pictograph labels are located, as shown, on the lift power unit column.
- B. Observe and heed Safety and Warning labels on the lift.

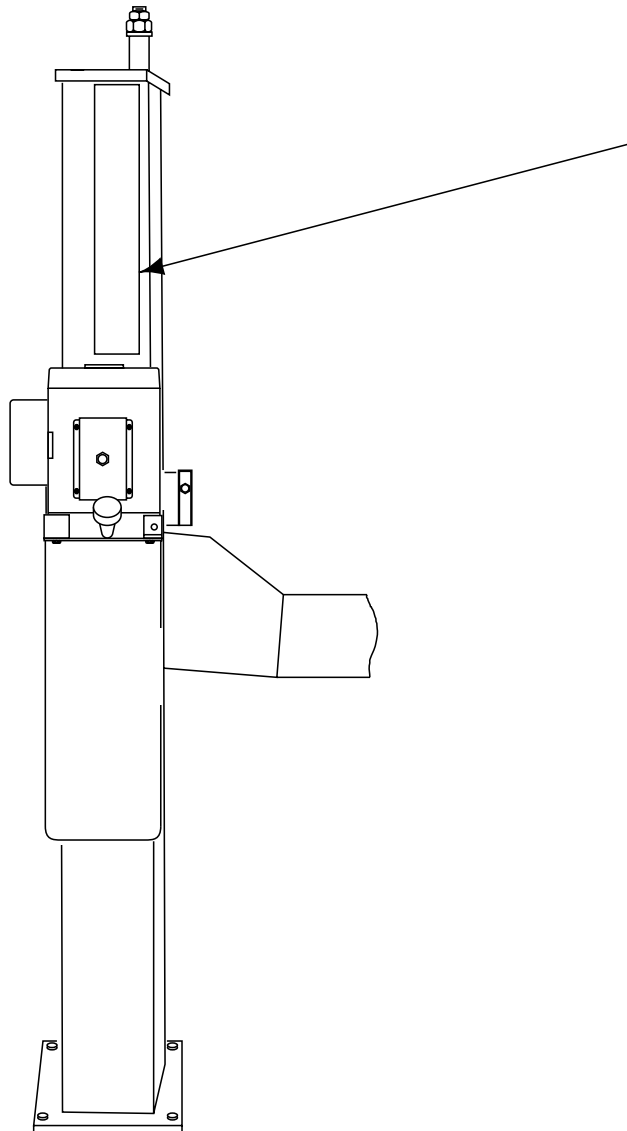

Fig. 1

<p>CAUTION</p> <p>Lift to be used by trained operator ONLY.</p>	<p>CAUTION</p> <p>Authorized personnel only in lift area.</p>
<p><small>The messages and pictographs shown are generic in nature and are meant to generally represent hazards common to all automotive lifts regardless of specific style.</small></p> <p><small>Funding for the development and validation of these labels was provided by the Automotive Lift Institute, PO Box 1519 New York, NY, 10101-1519.</small></p> <p><small>They are protected by copyright. Set of labels may be obtained from ALI or its member companies.</small></p> <p><small>© 1992 by ALI, Inc. ALI/WL200c</small></p>	
<p>SAFETY INSTRUCTIONS</p> <p>Read operating and safety manuals before using lift.</p>	<p>SAFETY INSTRUCTIONS</p> <p>Proper maintenance and inspection is necessary for safe operation.</p>
<p>SAFETY INSTRUCTIONS</p> <p>Do not operate a damaged lift.</p>	<p><small>The messages and pictographs shown are generic in nature and are meant to generally represent hazards common to all automotive lifts regardless of specific style.</small></p> <p><small>Funding for the development and validation of these labels was provided by the Automotive Lift Institute, PO Box 1519 New York, NY, 10101-1519.</small></p> <p><small>They are protected by copyright. Set of labels may be obtained from ALI or its member companies.</small></p> <p><small>© 1992 by ALI, Inc. ALI/WL200s</small></p>
<p>WARNING</p> <p>Clear area if vehicle is in danger of falling.</p>	<p>WARNING</p> <p>Remain clear of lift when raising or lowering vehicle.</p>
<p>WARNING</p> <p>Keep clear of pinch points when lift is moving.</p>	<p>WARNING</p> <p>Keep feet clear of lift while lowering.</p>
<p>WARNING</p> <p>Do not override self-closing lift controls.</p>	<p>WARNING</p> <p>Chock wheel to prevent vehicle movement.</p>
<p><small>The messages and pictographs shown are generic in nature and are meant to generally represent hazards common to all automotive lifts regardless of specific style.</small></p> <p><small>Funding for the development and validation of these labels was provided by the Automotive Lift Institute, PO Box 1519 New York, NY, 10101-1519.</small></p> <p><small>They are protected by copyright. Set of labels may be obtained from ALI or its member companies.</small></p> <p><small>© 1992 by ALI, Inc. ALI/WL200w</small></p>	

OPERATING INSTRUCTIONS

⚠️ WARNING To avoid personal injury and/or property damage, permit only trained personnel to operate lift. After reviewing these instructions, get familiar with lift controls by running the lift through a few cycles before loading vehicle on lift. Observe and heed SAFETY and WARNING labels on the lift.

Loading:

1. Lift must be fully lowered and no one in service bay while the vehicle is brought on lift.
2. Drive vehicle onto lift and center it on runways. At all times, be sure rear wheels are forward of the ramp/chocks and the ramp/chocks will clear tires when the lift is raised, Fig. 2. Driver and passengers must exit before raising.
3. Place triangular wheel chocks on each side of one rear tire, Fig. 2.

Raise Lift:

1. Push the RAISE button on the power unit. Release button at desired height, Fig. 3.
2. Lower onto locks.

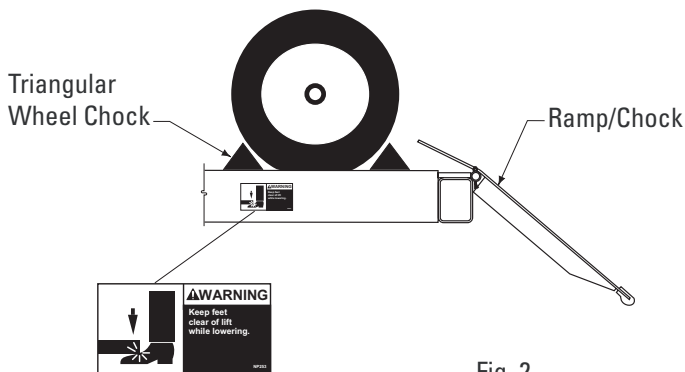

Fig. 2

Before Lowering Lift:

Be sure no one is in the lift area and that all tools, tool trays, etc. have been removed from under the lift.

⚠️ WARNING The runways, ramps and connecting yokes at each end of lift are designed to rest on the floor when fully lowered. Observe pinch point warning decals.

To Lower Lift:

Note: If button on air valve is released, the latches will automatically reset to the engaged position.

1. If lift has been resting on the locking latches, lift must be raised high enough for all four latches to clear the latch bar slots inside the columns.
2. Push the latch release button on power unit, Fig. 3, to disengage all four (4) locking latches.
3. Keeping the latch release button depressed, push lowering valve handle on the power unit to lower lift, Fig. 3. Lowering speed can be controlled by the force applied to the lowering valve handle.
4. Observe lift and vehicle to be sure lift is level while being lowered. If not, **STOP**. Repeat Steps 1 through 4.
5. Fully lower lift, remove the triangular wheel chocks and check to be sure area is clear before removing vehicle from lift.
6. If your lift is not operating properly, **DO NOT** use until adjustments or repairs have been made by qualified lift service personnel.

⚠️ CAUTION Keep hands clear of yoke ends while the lift is being raised or lowered, Fig. 4.

*Maximum operation pressure is:

2973 psi for SM30

2320 psi for RFL25

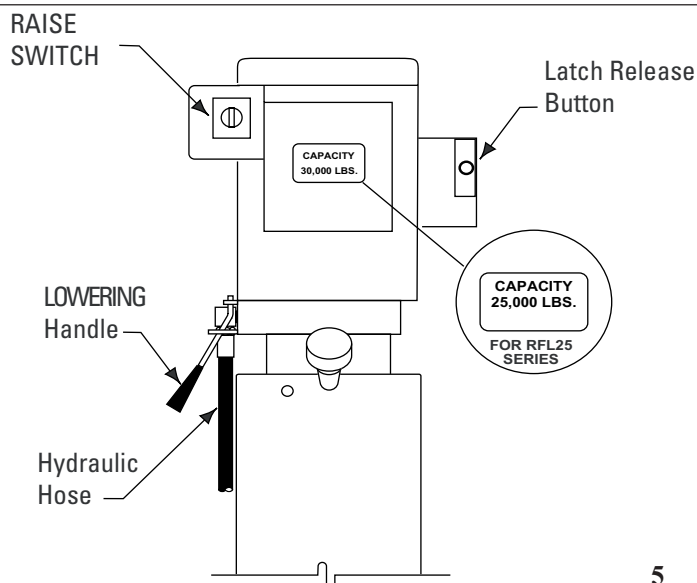

Fig. 3

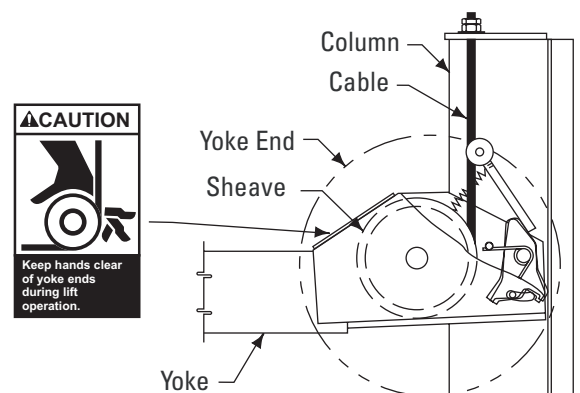

Fig. 4

Maintenance Instructions

⚠️ WARNING If you are not completely familiar with automotive lift maintenance procedures, **STOP:** Contact factory for instructions.

To Avoid Personal Injury, permit only qualified lift service personnel to perform maintenance on this equipment.

- **Use** only genuine replacement Parts for repairs.
- **Always:** Raise lift when cleaning floor area.
- **After First 2 Weeks of Usage:** Check cable adjustment per installation instructions. Continue to check cables per maintenance schedule below.
- **After First 2 Weeks of Usage:** Check torque on the column anchor bolts per installation instructions. Continue to check anchor bolts per maintenance schedule that follows.
- **Daily:** Check all column, lift/runway attaching bolts for tightness.
- **Daily:** Check cables and sheaves for wear. Observe for frayed cable strands. Wipe cables with a rag to detect hard to see small broken cable strands. Replace cables showing any broken strands. Replace worn parts as required with genuine parts.

- **Daily:** Inspect front wheel stops and ramp/chocks for damage or excessive wear. Replace as required.
- **Daily:** Check locking latch operation and reset. Adjust per instructions or repair if required.

⚠️ WARNING If slack cable arm is bent, replace immediately. Refer to illustration below.

- **Monthly:** Check torque on the column anchor bolts per specifications in installation instructions.
- **Monthly:** Check equalizer cable tension. Adjust per lift installation instructions. If there are no more threads available for adjustment, replace the cable. Do not use washers to stand off the nut to use previously used threads.
- **Semi-Annually:** Check fluid level of lift power unit and refill if required. If fluid is required, inspect all fittings, hoses, and seals. Repair as required.

IMPORTANT Cable adjustment should be checked by an authorized installer after the first 50 loaded lift cycles and after 300 loaded lift cycles.

Replace Bent Slack Cable Arm

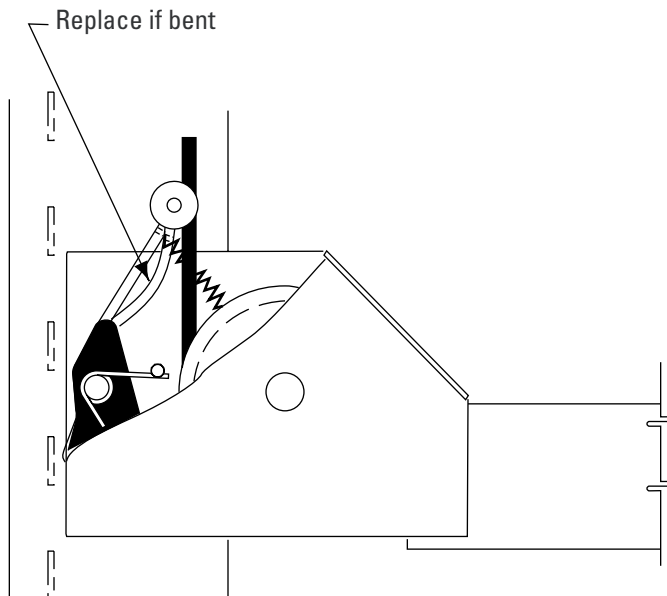

Fig. 5

Trouble Shooting

Trouble	Cause	Remedy
Motor does not run.	<ol style="list-style-type: none"> 1. Check fuse or circuit breaker. 2. Check for correct voltage to motor. 3. Inspect all wiring connections. 4. Switch burned out. 5. Motor windings burned out. 	<ol style="list-style-type: none"> 1. Replace blown fuse or reset circuit breaker. 2. Supply correct voltage to motor. 3. Repair and insulate all connections. 4. Replace switch. 5. Replace motor.
Motor runs but will not raise lift.	<ol style="list-style-type: none"> 1. Open lowering valve. 2. Pump sucking air. 3. Suction stub off pump. 4. Low fluid level. 	<ol style="list-style-type: none"> 1. Repair or replace lowering valve. 2. Tighten all suction line fittings. 3. Replace suction stub. 4. Fill tank with Dexron III ATF.
Motor runs—raises unloaded lift but will not raise vehicle.	<ol style="list-style-type: none"> 1. Motor running on low voltage. 2. Trash in lowering valve. 3. Improper relief valve adjustment. 4. Overloading lift. 	<ol style="list-style-type: none"> 1. Supply correct voltage to motor. 2. Clean lowering valve. 3. Replace relief valve cartridge. 4. Check vehicle weight and/or balance vehicle weight on lifts.
Lift slowly settles down.	<ol style="list-style-type: none"> 1. Trash in check valve seat. 2. Trash in lowering valve seat. 3. External fluid leaks. 	<ol style="list-style-type: none"> 1. Clean check valve. 2. Clean lowering valve. 3. Repair external leaks.
Slow lifting speed or fluid blowing out filler breather cap.	<ol style="list-style-type: none"> 1. Air mixed with fluid. 2. Air mixed with fluid suction. 3. Fluid return tube loose. 	<ol style="list-style-type: none"> 1. Change fluid to Dexron III ATF. 2. Tighten all suction line fittings. 3. Reinstall fluid return tube.
Lift going up unlevel.	<ol style="list-style-type: none"> 1. Cables out of adjustment. 2. Lift installed on unlevel floor. 	<ol style="list-style-type: none"> 1. Adjust slack out of cable. 2. Shim lift to level columns (Not to exceed 2"). <p>Note: Maximum shim thickness of 2" is possible by using shim kit. Contact your Product Service Consultant for ordering information.</p>
Lift stops short of full rise or chatters.	<ol style="list-style-type: none"> 1. Low on fluid. 	<ol style="list-style-type: none"> 1. Check fluid level and bleed cylinder. If fluid is required inspect all fittings, hoses, and seals. Repair as required.
Anchors will not stay tight.	<ol style="list-style-type: none"> 1. Holes drilled oversize. 2. Concrete floor thickness or holding strength not sufficient. 	<ol style="list-style-type: none"> 1. Use a fast setting cement to pour into oversize holes and reset anchors or relocate lift using a new bit to drill holes. 2. Break out old concrete and repour new pads for lift per installation instructions.
Lift will not lower.	<ol style="list-style-type: none"> 1. Insufficient air supply to lift. 2. Latches out of adjustment. 	<ol style="list-style-type: none"> 1. Check air pressure. Air supply to lift should be between: Min. 100 p.s.i. and Max. 120 p.s.i. Check all lines and fittings for leaks or crimps. Repair or replace as required. 2. Check latches per installation instructions.

Trouble Shooting

Trouble

Lift will not raise off of latches.

Cause

1. Motor, pump, or cylinder failure.

Remedy

1. Contact lift manufacturer's Customer Service.

Lift Lockout/Tagout Procedure

Purpose

This procedure establishes the minimum requirements for the lockout of energy that could cause injury to personnel by the operation of lifts in need of repair or being serviced. All employees shall comply with this procedure.

Responsibility

The responsibility for assuring that this procedure is followed is binding upon all employees and service personnel from outside service companies (i.e., authorized installers, contactors, etc.). All employees shall be instructed in the safety significance of the lockout procedure by the facility owner/manager. Each new or transferred employee along with visiting outside service personnel shall be instructed by the owner/manager (or assigned designee) in the purpose and use of the lockout procedure.

Preparation

Employees authorized to perform lockout shall ensure that the appropriate energy isolating device (i.e., circuit breaker, fuse, disconnect, etc.) is identified for the lift being locked out. Other such devices for other equipment may be located in close proximity of the appropriate energy isolating device. If the identity of the device is in question, see the shop supervisor for resolution. Assure that proper authorization is received prior to performing the lockout procedure.

Sequence of Lockout Procedure

- 1) Notify all affected employees that a lockout is being performed and the reason for it.
- 2) Unload the subject lift. Shut it down and assure the disconnect switch is "OFF" if one is provided on the lift.
- 3) The authorized lockout person operates the main energy isolation device removing power to the subject lift.
 - If this is a lockable device, the authorized lockout person places the assigned padlock on the device to prevent its unintentional reactivation. An appropriate tag is applied stating the person's name, at least 3" x 6" in size, an easily noticeable color, and states not to operate device or remove tag.
 - If this device is a non-lockable circuit breaker or fuse, replace with a "dummy" device and tag it appropriately as mentioned above.
- 4) Attempt to operate lift to assure the lockout is working. Be sure to return any switches to the "OFF" position.
- 5) The equipment is now locked out and ready for the required maintenance or service.

Restoring Equipment to Service

- 1) Assure the work on the lift is complete and the area is clear of tools, vehicles, and personnel.
- 2) At this point, the authorized person can remove the lock (or dummy circuit breaker or fuse) & tag and activate the energy isolating device so that the lift may again be placed into operation

Rules for Using Lockout Procedure

Use the Lockout Procedure whenever the lift is being repaired or serviced, waiting for repair when current operation could cause possible injury to personnel, or for any other situation when unintentional operation could injure personnel. No attempt shall be made to operate the lift when the energy isolating device is locked out.

Operating Conditions

Lift is not intended for outdoor use and has an operating ambient temperature range of 41°-104°F (5°-40°C).

APPROVED ACCESSORIES		
Item	Capacity	Part Number
Air/Electric Utility Box		FA915
Air/Electric Utility Box Without FRL		FA916
Rolling Jack	15,000 lbs.	RJ15000

Notes

Certificate of Compliance

Rotary Lift is authorized to apply ETL & cETL Listing Marks/Labels to this AC Motor. Authorization: ETL Report No. J98007541-003, FAM. This ETL test certifies that this AC Motor complies with Underwriters Laboratories, Inc. standard ANSI/UL 201 & CSA standard C22.2 No. 68.



SV0021 B Rev. 5/2/14

Trained Operators and Regular Maintenance Ensures Satisfactory Performance of Your Rotary Lift.

Replacement Parts: See installers package for parts breakdown sheet. Order Genuine Rotary replacement parts from your nearest Authorized Parts Distributor.

Maintenance Assistance: Contact your local Rotary distributor.

Should further assistance be required, contact Rotary Lift, at one of the phone numbers listed below.

Rotary World Headquarters

2700 Lanier Drive
Madison, IN 47250, USA
www.rotarylif.com

North America Contact Information

Tech. Support:
p 800.445.5438
f 800.578.5438
e userlink@rotarylif.com
Sales:
p 800.640.5438
f 800.578.5438
e userlink@rotarylif.com

World Wide Contact Information

World Headquarters/USA: 1.812.273.1622
Canada: 1.905.812.9920
European Headquarters/Germany: +49.771.9233.0
United Kingdom: +44.178.747.7711
Australasia: +60.3.7660.0285
Latin America / Caribbean: +54.3488.431.608
Middle East / Northern Africa: +49.771.9233.0

© Vehicle Service GroupSM

Printed in U.S.A., All Rights Reserved. Unless otherwise indicated, ROTARY, and all other trademarks are property of Dover Corporation and its affiliates.

